

Design and Optimization of New Smoke Exhaust Pipe for Mining Trucks

Qian WANG, Cheng XIN, Jialei ZHOU, Liang HAN*

Yingkou Institute of Technology, Yingkou, Liaoning, 115004, China

*Corresponding Author: Liang HAN, E-mail: 312462525@163.com

Abstract:

In order to improve the maintenance efficiency, extend the use time, ensure that the exhaust emission meets the standard, for the 830E truck heating bucket exhaust pipe design defects, the current single smoke exhaust system is transformed into a time period, convertible smoke exhaust system. After the transformation, it can not only realize the side row to prevent direct corrosion of the box bucket in summer, but also realize the heating of the box bucket at low temperature in winter to prevent snow and ice and frozen resources from sticking to the box bucket and the materials transported. After the transformation can save a lot of manpower, material resources, financial resources, improve the service life.

Keywords: smoke exhaust pipe; mining truck; extended use

1 Background and Significance

The smoke exhaust system of 830E mining truck adopts the design of heated pipe exhaust pipe, and the smoke exhaust also has the role of heating. In winter, there is much rain and snow in northern China, and it is easy to freeze materials. Prevent material freezing through the heating of the exhaust pipe. But in summer, the heating effect is ineffective, and the smoke is washed all the year round, which is easy to cause the phenomenon of aging and corrosion inside the smoke pipe. In order to reduce the corrosion of the smoke exhaust system on the inner compartment, the current single heated compartment pipe exhaust system is transformed into a time period and convertible smoke exhaust system. Disconnect the original pipe below the platform, install the three-way pipe, and have the system conversion function. In this way, the mode of "smoke exhaust + heating" is adopted in winter, and the single smoke exhaust mode is adopted in summer, which reduces the smoke erosion by three quarters, which fundamentally improves the service life and reduces the failure rate.

2 Design Ideas

When needed, the smoke exhaust mode should be converted at will. The conversion should ensure the sealing of the changing chamber, and no smoke leakage in the closing direction. Smoke exhaust box change valve timely conversion; The transformation process takes into

account the possible impact of the smoke exhaust system change on the engine power, To design it properly, Reasonable layout; The transformation process should fully consider the impact of the change of the smoke exhaust system on the temperature environment change around the engine smoke exhaust pipeline, To arrange the pipe layout of the smoke exhaust pipe reasonably, To achieve the minimum impact on the surrounding pipeline; The modification scheme shall fully consider the existing installation position of the left and right diesel tank and hydraulic fuel tank, During the renovation process, Keep a safe distance from all pipes on the car; Smoke exhaust system transformation of all materials using high-temperature resistant materials, Use of ferrite stainless steel; For the minimum transformation of the original exhaust pipe, The modified interface should be consistent with the existing smoke exhaust interface.

The layout and method of the 830E truck exhaust pipe before the transformation are as follows:

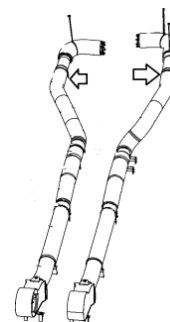

Figure 1 The layout diagram of the front row pipe

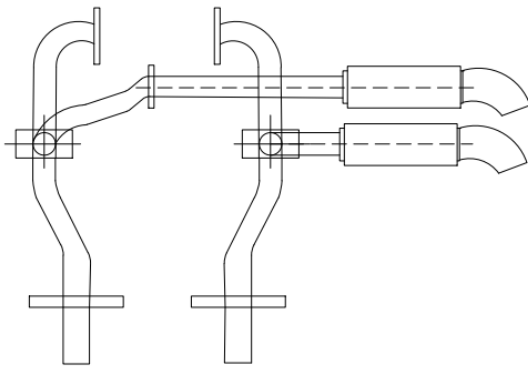

Figure 2 The layout diagram of the smoke exhaust pipe after the renovation

3 Specific Methods

(1) Location selection. Smoke pipe front for engine related smoke parts, quantity, complex structure, transformation space is very limited, so the front add side is difficult, then after the pump concentration area, pipeline, considering safety factors, is also unfavorable to add side, so choose in the middle, the rear support beam bridge selection position add side device is the most reasonable, the middle pipe completely modified, from the original exhaust pipe front interface connection, high and low parallel arrangement, fixed installation on the right side of the platform.

(2) Function implementation. In completely reserved before and after the smoke pipe case, the middle exhaust pipe (support interface after the beam to the main first interface) for modification, this section add or redesign a tee tube, respectively connect the front, back and side device, and the tee pipe has the valve can respectively realize the front-three-back-front-three-side device corresponding smoke function, to achieve the purpose of free switch.

(3) Related parameter design of smoke exhaust pipe:
 ①straight section span smoke exhaust pipe, the material is aluminized steel, surface spraying rust prevention, corrosion prevention, high temperature resistance and other polymerization materials, groove inner diameter of $\varphi_{\text{concave}}=240$ mm, convex along the outer diameter $\varphi_{\text{bulge}}=235$ mm, outer edge diameter $\varphi_{\text{outside}}=250$ mm, two lengths and sizes, short pipe $L_{\text{short}}=500$ mm, long tube $L_{\text{long}}=2450$ mm, the groove and the convex edge form a groove connection mode, the outer edge surface is fastened by a clamp, the two end of the section of the pipe is the groove surface, and the other end is the convex edge surface.
 ②The middle three-way exhaust pipe, T-shaped three-way pipe, the material uses the same straight span pipe, the front and rear ends are respectively groove, convex edge design, the vertical end has no processing process, each diameter is the same as the straight section exhaust pipe, the length of each end is

$L_{\text{Through}}=430$ mm, a leaf surface valve device is designed and installed at the rear end and the vertical end of the three links. The external control mechanism can effectively drive the valve to rotate 360° , and the leaf surface can open or close the channel with the rotation, so as to achieve the purpose of changing the direction of smoke exhaust fluid.
 ③90° bent smoke exhaust pipe, the main function is to change the three-way vertical end direction to the silencer, so that the smoke exhaust direction changes from vertical to horizontal to right. Its design parameters are: bending angle DOB value is 90° , space angle POB value is 283° , and each diameter angle is the same as the above smoke exhaust pipe.



Figure 3 Physical drawing of reversing room



Figure 4 Overall physical drawing of row of smoke pipe

4 Related Accessories

4.1 Fire proof cloth

Transformation process to fully consider the smoke system to the engine exhaust pipe surrounding the temperature of the environment changes, to reasonable layout of smoke pipe layout, to do minimum influence, the surrounding pipe fire need to measure custom, after the modification of fire cloth bandage not cracks should be completely fit, fire cloth should have protective layer, heat insulation layer, appearance oil high temperature resistant silicone fire layer, insulation cotton thickness is not less than 2.5cm, fire bag cloth with high temperature resistant ceramic fiber cotton, fiber cloth, steel wire mesh, heat insulation nails according to the modification of the smoke pipe shape.



Figure 5 Fire protection cloth

4.2 Silencer



Figure 6 Silencer

Resistance silencer, the straight tube multi-chamber structure is suitable for large smoke flue, its principle is the use of porous and related sound-absorbing materials to reduce the noise, in the process of acoustic transmission, the pipe cross-sectional area or internal resonance chamber can cause the change of acoustic impedance, sound energy reflection and consumption, sound absorption material fixed in the smoke circulation wall or the resonance chamber, when the sound wave into the silencer, part of the sound energy in the pores of the porous material and friction into heat dissipation, sound wave weakened. The muffler has a good effect on high frequency noise. The internal material is 2 mm thick high temperature resistant, corrosion resistance metal plate, the surface is perforated

and rolled into a cylindrical, the pore diameter is about 5mm, the perforation rate is about 60%, the external surface is still the same straight span pipe material, processed into chamber welding and inner surface welding, the design size is: inner pipe diameter $\phi_{\text{inner}}=240\text{mm}$, outer tube diameter of $\phi_{\text{outside}}=400\text{mm}$, silencer length L elimination $=1420\text{mm}$.

5 Full Text Summary

Through the design and transformation, the service life of the exhaust pipe is improved, the service time of the 830E mining truck exhaust system is longer, the service life of the truck exhaust pipe is more than 20,000 hours, the maintenance cost is reduced, and a lot of manpower, material resources and financial resources can be saved after the transformation.

Fund Project: (1) 2022 Liaoning Natural Science Foundation Plan (Yingkou Joint Fund) Damping damping Design and Optimization of New Bore Head Transmission Structure (Fund No.: 2022-YKLH-17); (2) In 2023, the key scientific research project of Yingkou Institute of Technology is the Design and Optimization of Smoke Drainage Pipe for New Mining Truck (Fund No.: ZDIL202306); (3) 2021 Natural Science Foundation of Liaoning Province (Yingkou Joint Fund) Research on Dynamic Characteristics of Damped Dynamic Reduction Vertical Holack (Fund No.: 2021-YKLH-08).

References

- [1] Xie Xiaomei. Optimization of ship engine room smoke exhaust pipe support design [J]. Journal of Qingdao Vocational College, 2021.3:66-75.
- [2] Cao Jijun. Study on the vibration characteristics of smoke exhaust pipe of ship main vessel [D]. Dalian University of Technology, 2016.
- [3] Huang Yilong, Zhang Shaogang, Shi Yanli. Analysis on the improvement effect of the lateral smoke exhaust efficiency of the distributed smoke exhaust pipe [J]. Fire Protection Science and Technology, 2022.4:107-130.
- [4] CAI Xiaotao, Dong Jiahuan, Huang Zhiwu ,et al.. Vibration reduction design of the main engine smoke exhaust pipe system of the scientific research vessel [J]. Ship Engineering, 2022.11:35-42.